

BASIC SERIAL COMMAND

FUNCTIONAL SPECIFICATIONS

PLC-XP50/XP55 (1.3" XGA V-4)
PLC-XP51/XP56 (1.3" XGA V-5)

SANYO Electric Co., Ltd
Consumer Group
AV Solutions Company
Projector BU

Records of Modification

Rev.	Date	Page	Content
	2004.11.17		New released
A			
B			
C			
D			
E			

Contents

1 . Overview	4
2 . Serial Interface Specification	4
2.1 . Transfer Specification	4
2.2 . Connection	4
3 . Notes for Communication	5
4 . Functional Execution Command Table	6
5 . Status Read Command Table	8
6 . Functional Execution Command	9
6.1 . Format	9
6.2 . Command Pipelining	9
6.3 . Transfer Example	9
6.4 . Operation Requirements	10
6.5 . POWER ON Command	11
6.6 . POWER OFF Command (Quick POWER OFF)	11
6.7 . POWER OFF Command	11
6.8 . INPUT 1 Command	11
6.9 . INPUT 2 Command	11
6.10 . INPUT 3 Command	12
6.11 . NETWORK Command	12
6.12 . VOLUME + Command	12
6.13 . VOLUME – Command	12
6.14 . AUDIO MUTE ON Command	12
6.15 . AUDIO MUTE OFF Command	13
6.16 . VIDEO MUTE ON Command	13
6.17 . VIDEO MUTE OFF Command	13
6.18 . SCREEN NORMAL SIZE Command	13
6.19 . SCREEN WIDE SIZE Command	13
6.20 . MENU ON Command	13
6.21 . MENU OFF Command	14
6.22 . DISPLAY CLEAR Command	14
6.23 . BRIGHTNESS + Command	14
6.24 . BRIGHTNESS – Command	14
6.25 . INPUT 2 VIDEO Command	14
6.26 . INPUT 2 Y,Pb/Cb,Pr/Cr Command	14
6.27 . INPUT 2 RGB Command	15
6.28 . IMAGE Command	15
6.29 . ON START SET Command	15
6.30 . ON START CANCEL Command	15
6.31 . POWER MANAGEMENT SET Command	15

6.32. POWER MANAGEMENT CANCEL Command.....	15
6.33. D.ZOOM + Command	16
6.34. D.ZOOM – Command.....	16
6.35. INPUT 3 VIDEO Command	16
6.36. INPUT 3 S-VIDEO Command	16
6.37. INPUT 3 Y,Pb/Cb,Pr/Cr Command	16
6.38. POINTER RIGHT Command.....	17
6.39. POINTER LEFT Command	17
6.40. POINTER UP Command	17
6.41. POINTER DOWN Command.....	17
6.42. MOUSE RIGHT CLICK Command.....	18
6.43. ENTER Command.....	18
6.44. FREEZE ON Command	18
6.45. FREEZE OFF Command.....	18
6.46. ZOOM + Command	18
6.47. ZOOM – Command	19
6.48. FOCUS + Command	19
6.49. FOCUS - Command	19
6.50. COLOR MANAGEMENT Command	19
6.51. INPUT 1 ANALOG RGB Command	19
6.52. INPUT 1 SCART Command.....	20
6.53. INPUT 1 DVI (PC DIGITAL) Command	20
6.54. INPUT 1 DVI (AV HDCP) Command	20
6.55. INPUT 1 MONITOR OUT Command.....	20
6.56. LENS SHIFT + Command.....	20
6.57. LENS SHIFT - Command.....	20
6.58. AUTO PC ADJ. Command	21
6.59. PRESENTATION TIMER Command	21
6.60. KEYSTONE ↑ Command	21
6.61. KEYSTONE ↓ Command	21
6.62. KEYSTONE → Command.....	21
6.63. KEYSTONE Command	21
7 . Status Read Command.....	23
7.1. Format.....	23
7.2. Transfer Example	23
7.3. Status Read Command	24
7.4. Input Mode Read Command.....	27
7.5. Lamp Time Read Command	27
7.6. Setting Read Command.....	27
7.7. Temp Read Command	28

1 . Overview

- 1.1. These specifications define projector control commands for PLC-XP50/XP55 (1.3" XGA V-4 model) and PLC-XP51/XP56 (1.3" XGA V-5 model).
- 1.2. The projector control commands are used to control a projector through RS-232C from a computer.

2 . Serial Interface Specification

2.1. Transfer Specification

Item	Specification
Synchronous system	Asynchronous
Transmission Speed	9600 / 19200
Data Length	8 bit
Parity	None
Stop Bit	1
Flow Control	None

Transmission speed: initial setting value is 19200.

Transmission speed can be changed by service mode.

2.2. Connection

Dedicated serial cable that comes with the projector must be used for a connection to a computer and projector.

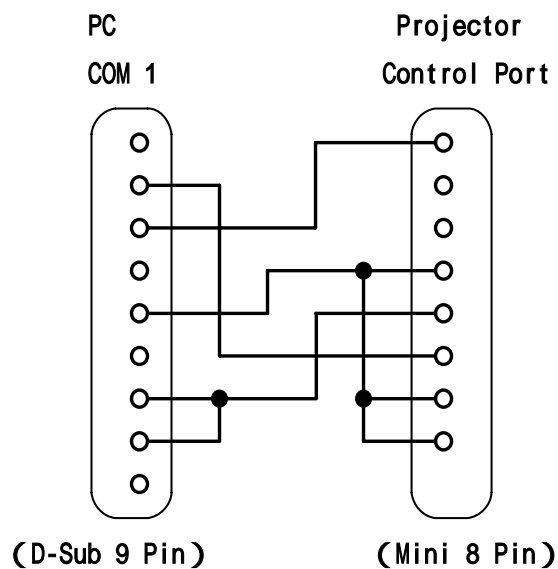

3 . Notes for Communication

3.1 The projector command is defined as one command/one line that starts with "C" and ends with carriage return (0x0D).

3.2 There are two types of commands, Functional Execution Command and Status Read Command.

Example of Functional Execution Command: "C05" [CR]

Example of Status Read Command: "CR0" [CR]

3.3 When it takes more than one second to receive one command, the function is not executed. When it takes more than one second until the projector receives carriage return since it has received the first data "C", it clears the information of buffer.

3.4 For the command pipelining, wait interval of 100 ms after the response.

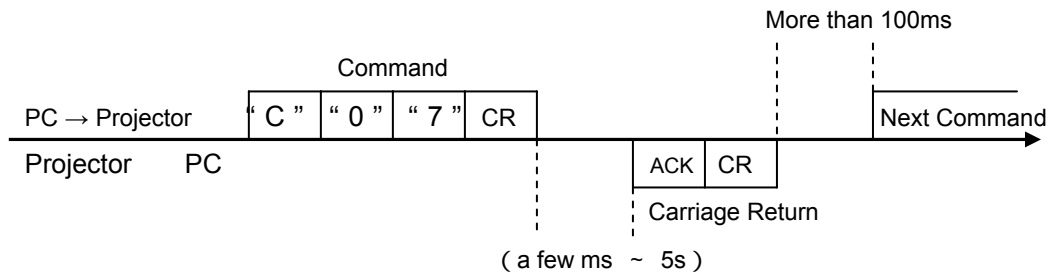

3.4.1 When a command is issued before receiving the response, the function is not executed properly.

3.4.2 Except when there is no response for 5 seconds.

3.5 It takes about 5 seconds for internal initialization after plugging in AC power. During this time, it cannot process commands. Do not issue any command.

3.6 The number of characters of response for Status Read Commands depends on commands. Please see [7. Status Read Command].

3.7 Characters for commands must be Capital (A - Z).

4 . Functional Execution Command Table

Command	Item	Command	Item
C00	POWER ON	C20	BRIGHTNESS +
C01	POWER OFF (QUICK POWER OFF)	C21	BRIGHTNESS -
C02	POWER OFF	C22	————
C03	————	C23	INPUT 2 VIDEO
C04	————	C24	INPUT 2 Y,Pb/Cb,Pr/Cr
C05	INPUT 1	C25	INPUT 2 RGB
C06	INPUT 2	C26	————
C07	INPUT 3	C27	IMAGE
C08	NETWORK	C28	ON START SET
C09	VOLUME +	C29	ON START CANCEL
C0A	VOLUME -	C2A	POWER MANAGEMENT SET
C0B	AUDIO MUTE ON	C2B	POWER MANAGEMENT CANCEL
C0C	AUDIO MUTE OFF	C2C	————
C0D	VIDEO MUTE ON	C2D	————
C0E	VIDEO MUTE OFF	C2E	————
C0F	SCREEN NORMAL SIZE (4:3)	C2F	————
C10	SCREEN WIDE SIZE (16:9)	C30	D.ZOOM +
C11	————	C31	D.ZOOM -
C12	————	C32	————
C13	————	C33	INPUT 2 VIDEO
C14	————	C34	INPUT 2 S-VIDEO
C15	————	C35	INPUT 2 Y,Pb/Cb,Pr/Cr
C16	————	C36	————
C17	————	C37	————
C18	————	C38	————
C19	————	C39	————
C1A	————	C3A	POINTER RIGHT
C1B	————	C3B	POINTER LEFT
C1C	MENU ON	C3C	POINTER UP
C1D	MENU OFF	C3D	POINTER DOWN
C1E	DISPLAY CLEAR	C3E	MOUSE RIGHT CLICK
C1F	————	C3F	ENTER

“————” means “No Function”.

Command	Item	Command	Item
C40		C80	
C41		C81	
C42		C82	
C43	FREEZE ON	C83	
C44	FREEZE OFF	C84	
C45		C85	
C46	ZOOM -	C86	
C47	ZOOM +	C87	
C48		C88	
C49		C89	AUTO PC ADJ.
C4A	FOCUS -	C8A	PRESENTATION TIMER
C4B	FOCUS +	C8B	
C4C		C8C	
C4D		C8D	
C4E	COLOR MANAGEMENT	C8E	KEYSTONE
C4F		C8F	KEYSTONE
C50	INPUT 1 ANALOG RGB	C90	KEYSTONE
C51	INPUT 1 SCART	C91	KEYSTONE
C52	INPUT 1 DVI (PC DIGITAL)	C92	
C53	INPUT 1 DVI (AV HDCP)	C93	
C54	INPUT 1 MONITOR OUT	C94	
C55		C95	
C56		C96	
C57		C97	
C58		C98	
C59	_____	C99	
C5A	_____	C9A	
C5B		C9B	
C5C		C9C	
C5D	LENS SHIFT +	C9D	
C5E	LENS SHIFT -	C9E	
C5F		C9F	

“_____” means “No Function”.

5 . Status Read Command Table

Command	Item	Note
CR0	Status Read	
CR1	Input Mode Read	
CR2		
CR3	Lamp Time Read	
CR4	Setting Read	
CR5		
CR6	Temp Read	
CR7		
CR8		
CR9		
CRA		
CRB		
CRC		

“———“ means “No Function”.

6 . Functional Execution Command

6 . 1 . Format

6 . 1 . 1 . PC issues a command in format as below:

“C” Command [CR]

Command: two characters (See Functional Execution Command Table)

6 . 1 . 2 . A projector decodes the received data and returns a result after being ready to receive next command.

[ACK] [CR] : (0x06, 0x0D) When received Functional Execution Commands.

6 . 1 . 3 . When received data cannot be decoded, it returns “?” [CR]

6 . 2 . When the command pipelining is needed

When some functions need the command pipelining, the performance is the same as the remote control's performance.

- 1) System: issue any command every 100 ms after receiving the response
- 2) When receiving the appropriate command, the function is executed for 120 ms from the moment.
- 3) When receiving the same command continuously within 120 ms, the function is executed for another 120 ms from the moment.
- 4) When there is no incoming command after 120 ms, the execution of pipelining is stopped.
- 5) When the projector receives other incoming commands within 120 ms, the execution of pipelining is stopped.

6 . 3 . Transfer Example

Change the projector's mode to video mode with Basic Command.

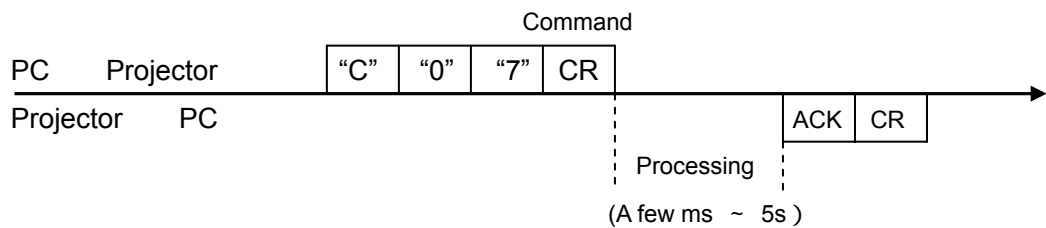

6.4. Operation Requirements

When the projector's status is in this below, Functional Execution Commands are limited.

Projector Status	Available Functional Execution Commands
Standby Mode	C00 : POWER ON
Processing Countdown	C00 : POWER ON Countdown is terminated C01 : POWER OFF C02 : POWER OFF Countdown is terminated
Processing Cooling Down	NONE (No Execution)
Cooling Down due to Abnormal Temperature	NONE (No Execution)
Abnormal Temperature Status	NONE (No Execution)
Processing Power Save / Cooling Down	NONE (No Execution)
Power Save Status	C00 : POWER ON C01 : POWER OFF Others : POWER ON
Processing Cooling Down after OFF due to Lamp Failure	NONE (No Execution)

Note) When the status is above, even if the projector receives other command, it returns **[ACK]**
[CR].

6.5. POWER ON Command

Command	"C00" [CR]	
Detail	Power ON When already Power is ON, no need to do. When sending this command during processing Countdown, Countdown is terminated.	
Response	Acceptable	[ACK] [CR]
	Unacceptable	"?" [CR]

6.6. POWER OFF Command (Quick POWER OFF)

Command	"C01" [CR]	
Detail	Power OFF (Standby) When Power is OFF with ON-OFF button of the projector and remote control, "Power OFF?" is displayed. However, as soon as this command is sent, Quick Power OFF is executed.	
Response	Acceptable	[ACK] [CR]
	Unacceptable	"?" [CR]

6.7. POWER OFF Command

Command	"C02" [CR]	
Detail	Power OFF (Standby) This command works the same as when Power is OFF with ON-OFF button of the projector and remote control. (When the command is sent once, "Power OFF ?" is displayed. If this command is sent again while "Power OFF ?" is displayed, Power OFF is executed.) When sending this command during processing Countdown, Countdown is terminated.	
Response	Acceptable	[ACK] [CR]
	Unacceptable	"?" [CR]

6.8. INPUT 1 Command

Command	"C05" [CR]	
Detail	Select Input 1	
Response	Acceptable	[ACK] [CR]
	Unacceptable	"?" [CR]

6.9. INPUT 2 Command

Command	"C06" [CR]	
Detail	Select Input 2	
Response	Acceptable	[ACK] [CR]
	Unacceptable	"?" [CR]

6.1 0. INPUT 3 Command

Command	"C07" [CR]	
Detail	Select Input 3	
Response	Acceptable	[ACK] [CR]
	Unacceptable	"?" [CR]

6.1 1. NETWORK Command

Command	"C08" [CR]	
Detail	Select Input for Network	
Response	Acceptable	[ACK] [CR]
	Unacceptable	"?" [CR]

6.1 2. VOLUME + Command

Command	"C09" [CR]	
Detail	Volume Up This command works the same as "VOLUME +" button of the projector and remote control.	
Response	Acceptable	[ACK] [CR]
	Unacceptable	"?" [CR]

6.1 3. VOLUME - Command

Command	"C0A" [CR]	
Detail	Volume Down This command works the same as "VOLUME -" button of the projector and remote control.	
Response	Acceptable	[ACK] [CR]
	Unacceptable	"?" [CR]

6.1 4. AUDIO MUTE ON Command

Command	"C0B" [CR]	
Detail	Sound Mute ON This command works the same as "MUTE" button of the remote control for Mute ON, but does not work for Mute OFF.	
Response	Acceptable	[ACK] [CR]
	Unacceptable	"?" [CR]

6.1 5. AUDIO MUTE OFF Command

Command	"C0C" [CR]	
Detail	Sound Mute OFF This command works the same as "MUTE" button of the remote control for Mute OFF, but does not work for Mute ON.	
Response	Acceptable	[ACK] [CR]
	Unacceptable	"?" [CR]

6.1 6. VIDEO MUTE ON Command

Command	"C0D" [CR]	
Detail	Video Mute ON This command works the same as "NO SHOW" button of the remote control for No Show ON, but does not work for No Show OFF.	
Response	Acceptable	[ACK] [CR]
	Unacceptable	"?" [CR]

6.1 7. VIDEO MUTE OFF Command

Command	"C0E" [CR]	
Detail	Video Mute OFF This command works the same as "NO SHOW" button of remote control for No Show OFF, but does not work for No Show ON.	
Response	Acceptable	[ACK] [CR]
	Unacceptable	"?" [CR]

6.1 8. SCREEN NORMAL SIZE Command

Command	"C0F" [CR]	
Detail	Set screen size to Normal (4:3)	
Response	Acceptable	[ACK] [CR]
	Unacceptable	"?" [CR]

6.1 9. SCREEN WIDE SIZE Command

Command	"C10" [CR]	
Detail	Set screen size to Wide (16:9)	
Response	Acceptable	[ACK] [CR]
	Unacceptable	"?" [CR]

6.2 0. MENU ON Command

Command	"C1C" [CR]	
Detail	Display On-Screen Display Menu	
Response	Acceptable	[ACK] [CR]
	Unacceptable	"?" [CR]

6.2 1. MENU OFF Command

Command	"C1D" [CR]	
Detail	Clear On-Screen Display Menu	
Response	Acceptable	[ACK] [CR]
	Unacceptable	"?" [CR]

6.2.2. DISPLAY CLEAR Command

Command	"C1E" [CR]	
Detail	Clear On-Screen Display Clear On-screen Display unconditionally	
Response	Acceptable	[ACK] [CR]
	Unacceptable	"?" [CR]

6.2.3. BRIGHTNESS + Command

Command	"C20" [CR]	
Detail	Brightness of User Control +1	
Response	Acceptable	[ACK] [CR]
	Unacceptable	"?" [CR]

6.2.4. BRIGHTNESS – Command

Command	"C21" [CR]	
Detail	Brightness of User Control -1	
Response	Acceptable	[ACK] [CR]
	Unacceptable	"?" [CR]

6.2.5. INPUT 2 VIDEO Command

Command	"C23" [CR]	
Detail	Select Video input of Input 2	
Response	Acceptable	[ACK] [CR]
	Unacceptable	"?" [CR]

6.2.6. INPUT 2 Y,Pb/Cb,Pr/Cr Command

Command	"C24" [CR]	
Detail	Select Y,Pb/Cb,Pr/Cr input of Input 2	
Response	Acceptable	[ACK] [CR]
	Unacceptable	"?" [CR]

6.2.7. INPUT 2 RGB Command

Command	"C25" [CR]	
Detail	Select RGB input of Input 2	
Response	Acceptable	[ACK] [CR]
	Unacceptable	"?" [CR]

6.2.8. IMAGE Command

Command	"C27" [CR]	
Detail	Switch Image Setting status This command works the same as "IMAGE" button on the projector or remote control.	
Response	Acceptable	[ACK] [CR]
	Unacceptable	"?" [CR]

6.2.9. ON START SET Command

Command	"C28" [CR]	
Detail	Set Power ON Start This status is stored in EEPROM and retained regardless of Power ON/OFF	
Response	Acceptable	[ACK] [CR]
	Unacceptable	"?" [CR]

6.3.0. ON START CANCEL Command

Command	"C29" [CR]	
Detail	Cancel Power ON Start This status is stored in EEPROM and retained regardless of Power ON/OFF	
Response	Acceptable	[ACK] [CR]
	Unacceptable	"?" [CR]

6.3.1. POWER MANAGEMENT SET Command

Command	"C2A" [CR]	
Detail	Set Power Management This status is stored in EEPROM and retained regardless of Power ON/OFF	
Response	Acceptable	[ACK] [CR]
	Unacceptable	"?" [CR]

6.3.2. POWER MANAGEMENT CANCEL Command

Command	"C2B" [CR]	
Detail	Cancel Power Management This status is stored in EEPROM and retained regardless of Power ON/OFF	
Response	Acceptable	[ACK] [CR]
	Unacceptable	"?" [CR]

6.3.3. D.ZOOM + Command

Command	"C30" [CR]	
Detail	Enter Digital Zoom mode and expand image size This command works the same as "D.ZOOM ▲" button of the remote control.	
Response	Acceptable	[ACK] [CR]
	Unacceptable	"?" [CR]

6.3.4. D.ZOOM – Command

Command	"C31" [CR]	
Detail	Enter Digital Zoom mode and compress image size This command works the same as "D.ZOOM ▼" button of the remote control.	
Response	Acceptable	[ACK] [CR]
	Unacceptable	"?" [CR]

6.3.5. INPUT 3 VIDEO Command

Command	"C33" [CR]	
Detail	Select Video input of Input 3	
Response	Acceptable	[ACK] [CR]
	Unacceptable	"?" [CR]

6.3.6. INPUT 3 S-VIDEO Command

Command	"C34" [CR]	
Detail	Select S-Video input of Input 3	
Response	Acceptable	[ACK] [CR]
	Unacceptable	"?" [CR]

6.3.7. INPUT 3 Y,Pb/Cb,Pr/Cr Command

Command	"C35" [CR]	
Detail	Select Y,Pb/Cb,Pr/Cr input of Input 3	
Response	Acceptable	[ACK] [CR]
	Unacceptable	"?" [CR]

6.3.8. POINTER RIGHT Command

Command	"C3A" [CR]	
Detail	Move the Pointer of On-Screen Display Menu to the right This command is different from Point button ">" of the projector in operation and has no "Volume +" function.	
Response	Acceptable	[ACK] [CR]
	Unacceptable	"?" [CR]

6.3.9. POINTER LEFT Command

Command	"C3B" [CR]	
Detail	Move the Pointer of On-Screen Display Menu to the left This command is different from Point button "<" of the projector in operation and has no "Volume -" function.	
Response	Acceptable	[ACK] [CR]
	Unacceptable	"?" [CR]

6.4 0. POINTER UP Command

Command	"C3C" [CR]	
Detail	Move up the Pointer of On-Screen Display Menu This command works the same as "▲" button of the projector.	
Response	Acceptable	[ACK] [CR]
	Unacceptable	"?" [CR]

6.4 1. POINTER DOWN Command

Command	"C3D" [CR]	
Detail	Move down the Pointer of On-Screen Display Menu This command works the same as "▼" button of the projector.	
Response	Acceptable	[ACK] [CR]
	Unacceptable	"?" [CR]

6.4 2. MOUSE RIGHT CLICK Command

Command	"C3E" [CR]	
Detail	This command works the same as "Mouse Right Click" button of the remote control.	
Response	Acceptable	[ACK] [CR]
	Unacceptable	"?" [CR]

6.4 3. ENTER Command

Command	"C3F" [CR]	
Detail	This command works the same as "SELECT" button of the projector and remote control.	
Response	Acceptable	[ACK] [CR]
	Unacceptable	"?" [CR]

6.4 4. FREEZE ON Command

Command	"C43" [CR]	
Detail	Freeze picture on-screen This command works the same as "FREEZE" button of the remote control for Freeze ON, but does not work for Freeze OFF.	
Response	Acceptable	[ACK] [CR]
	Unacceptable	"?" [CR]

6.4 5. FREEZE OFF Command

Command	"C44" [CR]	
Detail	Cancel Freeze function This command works the same as "FREEZE" button of the remote control for Freeze Off, but does not work for Freeze ON.	
Response	Acceptable	[ACK] [CR]
	Unacceptable	"?" [CR]

6.46. ZOOM + Command

Command	"C47" [CR]	
Detail	Expand image size This command works the same as "ZOOM ▲" button of the remote control.	
Response	Acceptable	[ACK] [CR]
	Unacceptable	"?" [CR]

6.47. ZOOM – Command

Command	"C46" [CR]	
Detail	Compress image size This command works the same as "ZOOM ▼" button of the remote control.	
Response	Acceptable	[ACK] [CR]
	Unacceptable	"?" [CR]

6.48. FOCUS + Command

Command	"C4B" [CR]	
Detail	Adjust focus of screen image (sharp and clear) with a long-focal-length () (the lens direction is backward) This command works the same as "FOCUS▲" button of the remote control.	
Response	Acceptable	[ACK] [CR]
	Unacceptable	"?" [CR]

6.49. FOCUS – Command

Command	"C4A" [CR]	
Detail	Adjust focus of screen image (sharp and clear) with a short-focal-length () (the lens direction is forward) This command works the same as "FOCUS ▼" button of the remote control.	
Response	Acceptable	[ACK] [CR]
	Unacceptable	"?" [CR]

6.50. COLOR MANAGEMENT Command

Command	"C4E" [CR]	
Detail	Set Color Management ON This command works the same as "COLOR M." button of the remote control.	
Response	Acceptable	[ACK] [CR]
	Unacceptable	"?" [CR]

6.51. INPUT 1 ANALOG RGB Command

Command	"C50" [CR]	
Detail	Select Analog RGB input of Input 1	
Response	Acceptable	[ACK] [CR]
	Unacceptable	"?" [CR]

6.5 2. INPUT 1 SCART Command

Command	"C51" [CR]	
Detail	Select SCART input of Input 1	
Response	Acceptable	[ACK] [CR]
	Unacceptable	"?" [CR]

6.5 3. INPUT 1 DVI (PC DIGITAL) Command

Command	"C52" [CR]	
Detail	Select DVI (PC Digital) input of Input 1	
Response	Acceptable	[ACK] [CR]
	Unacceptable	"?" [CR]

6.5 4. INPUT 1 DVI (AV HDCP) Command

Command	"C53" [CR]	
Detail	Select DVI (AV HDCP) input of Input 1	
Response	Acceptable	[ACK] [CR]
	Unacceptable	"?" [CR]

6.5 5. INPUT 1 MONITOR OUT Command

Command	"C54" [CR]	
Detail	Set Input 1 to Monitor Out	
Response	Acceptable	[ACK] [CR]
	Unacceptable	"?" [CR]

6.5 6. LENS SHIFT + Command

Command	"C5D" [CR]	
Detail	Move screen image Up by Lens Shift function	
Response	Acceptable	[ACK] [CR]
	Unacceptable	"?" [CR]

6.5 7. LENS SHIFT - Command

Command	"C5E" [CR]	
Detail	Move screen image Down by Lens Shift function	
Response	Acceptable	[ACK] [CR]
	Unacceptable	"?" [CR]

6.5 8. AUTO PC ADJ. Command

Command	"C89" [CR]	
Detail	Execute AUTO PC ADJ. function This command works the same as "AUTO PC ADJ." button of the remote control. When sending this command during processing Auto PC Adj., the operation of Auto PC Adj. is terminated. This is the same operation as "AUTO PC" button of the remote control.	
Response	Acceptable	[ACK] [CR]
	Unacceptable	"?" [CR]

6.5 9. PRESENTATION TIMER Command

Command	"C8A" [CR]	
Detail	Start Timer to count time for Presentation This command works the same as "P-TIMER" button of the remote control.	
Response	Acceptable	[ACK] [CR]
	Unacceptable	"?" [CR]

6.6 0. KEYSTONE ↑ Command

Command	"C8E" [CR]	
Detail	Correct keystone distortion by reducing upper part of image	
Response	Acceptable	[ACK] [CR]
	Unacceptable	"?" [CR]

6.6 1. KEYSTONE ↓ Command

Command	"C8F" [CR]	
Detail	Correct keystone distortion by reducing down part of image	
Response	Acceptable	[ACK] [CR]
	Unacceptable	"?" [CR]

6.6 2. KEYSTONE → Command

Command	"C90" [CR]	
Detail	Correct keystone distortion by reducing right part of image	
Response	Acceptable	[ACK] [CR]
	Unacceptable	"?" [CR]

6.6 3. KEYSTONE ← Command

Command	"C91" [CR]	
Detail	Correct keystone distortion by reducing left part of image	
Response	Acceptable	[ACK] [CR]
	Unacceptable	"?" [CR]

7 . Status Read Command

7.1. Format

7.1.1. PC issues commands in format as below:

“CR” **Command** [CR]

Command: one character (See [5. Status Read Command Table])

7.1.2. When a projector receives the appropriate command, it returns a character line as the required data.

Required Data [CR]

Required Data: A character line (See [5. Status Read Command Table])

7.1.3. When the received data cannot be decoded, the projector returns “?” [CR].

7.2. Transfer Example

Get input mode for projector by Basic Commands.

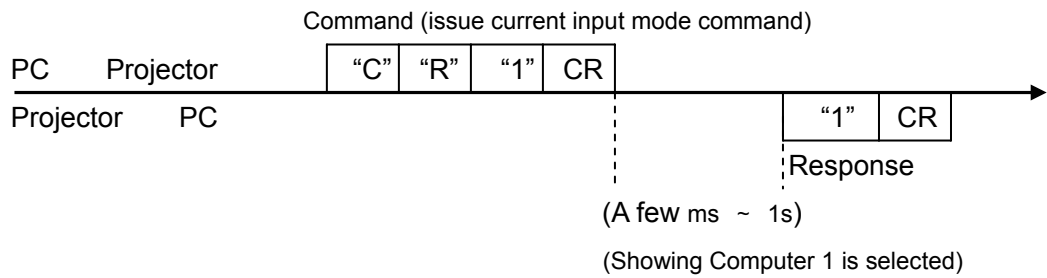

7.3. Status Read Command

Command	"CR0" [CR]	
Detail	Get the projector's operating status	
Response	Acceptable	"%1" [CR]
	%1	"00" = Power ON "80" = Standby "40" = Processing Countdown "20" = Processing Cooling Down "10" = Power Failure "28" = Processing Cooling Down due to Abnormal Temperature "08" = Abnormal Temperature "88" = Standby after Cooling Down due to Abnormal Temperature "24" = Processing Power-Save Cooling Down "04" = Power Save "21" = Processing Cooling Down after OFF due to Lamp Failure "81" = Standby after Cooling Down due to Lamp Failure
	Unacceptable	"?" [CR]

【Details for Response】

7.3.1. "00" [CR]

Status: Power ON

Normal image is on-screen.

7.3.2. "80" [CR]

Status: Standby

When the status is Standby, Status Read Commands are always acceptable, but Functional Execution Commands are not acceptable except POWER ON command.

7.3.3. "40" [CR]

Status: Processing Countdown

When "Display" in Setting Menu is ON and POWER ON is executed, it starts processing Countdown.

When "Display" in Setting Menu is OFF, processing Countdown is canceled and the status moves to Power ON quickly.

7.3.4. "20" [CR]

Status: Processing Cooling Down

When the status is Power ON, and POWER OFF Command ("C01"[CR]) is executed, it moves to Cooling Down status.

This status automatically moves to Standby when lamp turns off and the fan spin finishes after about 90 seconds. (The fan spin time depends on models.)

This function is used to cool down lamps and other optical parts, and is quite important for projector's liability. During this time, Functional Execution Commands are invalid.

7.3.5. “10” [CR]

Status: Power Failure

When the power supply voltage inside the projector reaches abnormal status, the projector is automatically turned off. The projector returns “10” [CR], which shows it moves to Power OFF status due to Power Failure.

Fan also stops unlike Cooling Down status.

7.3.6. “28” [CR]

Status: Processing Cooling Down due to Abnormal Temperature

When the inside temperature becomes abnormally high, it automatically starts Cooling Down. Response for this status is “28” [CR].

Even if the temperature decreases during this process, Cooling Down is executed.

7.3.7. “08” [CR]

Status: Abnormal Temperature

When the inside temperature does not go down even after Cooling Down, the projector returns “08” [CR] as response for this status.

Projector maintains the Standby mode.

7.3.8. “88” [CR]

Status: Standby after Cooling Down due to Abnormal Temperature

When temperature goes up to the abnormal status, it starts Cooling Down and moves to Standby mode, the projector returns “88” [CR] which shows it moves to Standby status due to Abnormal Temperature.

This status will be kept till the next operation takes place. When Power On is executed, it cancels the information on Abnormal Temperature and normal operation takes place.

7.3.9. “24” [CR]

Status: Processing Power Save / Cooling Down

Power Management function in the Setting menu works and the status goes to Power Save/Cooling Down.

During this time, any Functional Execution Commands are invalid.

The status moves to Power Save at set hours after the operation of Power Save/Cooling Down function.

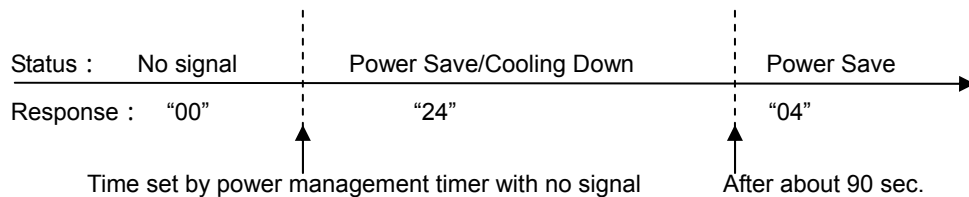

7.3.1 0. “04” [CR]

Status: Power Save

This shows it moves to Power-Save status by Power Management function in the Setting menu.

7.3.1 1. “21” [CR]

Status: Processing Cooling Down after OFF due to Lamp Failure

When the projector is turned off because of lamp failure, it automatically starts Cooling Down. Response for this status is “21” [CR].

The response command “21” [CR] maintains during Cooling Down.

7.3.1 2. “81” [CR]

Status: Standby after Cooling Down due to Lamp Failure

The projector status is restored from lamp failure.

When the status moves to Standby after Cooling Down due to lamp failure, it returns “81”.

This shows the status turns to Standby because of lamp failure. This status maintains until next operation is done.

When Power ON is executed, the information on lamp failure is canceled and normal operation is executed.

7.4. Input Mode Read Command

Command	"CR1" [CR]	
Detail	Get selected Input No.	
Response	Acceptable	"%1" [CR]
	%1	"1" = Input 1 is selected. "2" = Input 2 is selected. "3" = Input 3 is selected. "4" = Input (Network Viewer) is selected.
	Unacceptable	"?" [CR]

7.5. Lamp Time Read Command

Command	"CR3" [CR]	
Detail	Get total lamp running hours.	
Response	Acceptable	"%1" [CR]
	%1	Display Lamp running hours with 4 digit numbers. Example: "0410" [CR] 410 hours
	Unacceptable	"?" [CR]

7.6. Setting Read Command

Command	"CR4" [CR]	
Detail	Get screen setting status such as Ceiling/Rear.	
Response	Acceptable	"%1" [CR]
	%1	"11" [CR] = Normal Screen Setting "10" [CR] =Picture is top/bottom reversed. (Status: Rear & Ceiling ON) "01" [CR] = Picture is left/right reversed. (Status: Rear ON) "00" [CR]=Picture is top/bottom and left/right reversed. (Status: Ceiling ON)
	Unacceptable	"?" [CR]

7.7. Temp Read Command

Command	"CR6" [CR]	
Detail	Get the temperature inside a projector. With some built-in temperature sensors, it can get all the temperatures at once.	
Response	Acceptable	"%1 _ %2 _ %3" [CR]
	%1 %2 %3	%1 = Temp. of sensor 1 %2 = Temp. of sensor 2 %3 = Temp. of sensor 3 Temp. data form is shown as "00.0". When the temp. sinks to -, the first character is " -" like "-05.5" [CR]. When no temp. data returns due to hardware problems, the first character is "E" like"E00.0" [CR]. With some built-in temp. sensors, the projector sends commands continuously. "_ 31.5 _ 35.2 _ 33.4 " [CR] There is the first sensor's data, one space, the second sensor's data.
	Unacceptable	"?" [CR]

PROTECTION SHEET